

Okeechobee County Community Development Department
1700 NW 9th Avenue ▪ Suite A; Okeechobee, FL 34972
Phone (863) 763-5548 ▪ Fax (863) 763-5276

Affidavit for Electric Service for a 60 amp Service

I, _____, of _____
(Name) (Mailing Address)

hereby request electrical service at _____,

Parcel Number _____

for the purpose of _____

I am requesting an electrical service for the reason(s) as stated above. I understand and agree that any extension, expansion, or use of the electrical service must be in accordance with the Code of Ordinances of Okeechobee County and the laws of the State of Florida, and that additional permits for such extensions, expansions or uses may be required.

I understand that when electrical service is permitted for the maintenance or installation of landscaping or ground cover, that it is a violation of Okeechobee County regulations to use the service otherwise, unless a permit has been obtained for that use.

I understand that in residential zoning districts and for parcels in agricultural zoning districts under five (5) acres in area that animals and the care of animals is considered an accessory use. Therefore no animals shall be placed on the property unless there is a single family dwelling with a final certificate of occupancy issued.

I understand that if I use a permitted electric service for other than the stated purpose of the service that the service may be disconnected at my expense, and I hereby consent to termination of power by the provider under such circumstances. I understand that re-in statement of electric service for a permitted use will also be at my expense, and that a permit is required. I understand that power may not be reinstated until appropriate permits have been obtained, or until the non-agricultural use or other unauthorized use has been terminated or removed from the premises.

Print Owner Name

Signature of Property Owner

STATE OF FLORIDA
COUNTY OF OKEECHOBEE

Sworn to and subscribed before me this _____ day of _____, 20____. Personally known to me _____ OR produced _____ as identification and did not take on oath.

Notary Public - State of Florida

SEAL

For Office Use Only

Zoning of Property _____

Zoning Approval _____

60 AMP

Electric Service Standards

SUBJECT

IV. SERVICE and METER CONNECTIONS

FIGURE IV-13a

Remote Meter Location

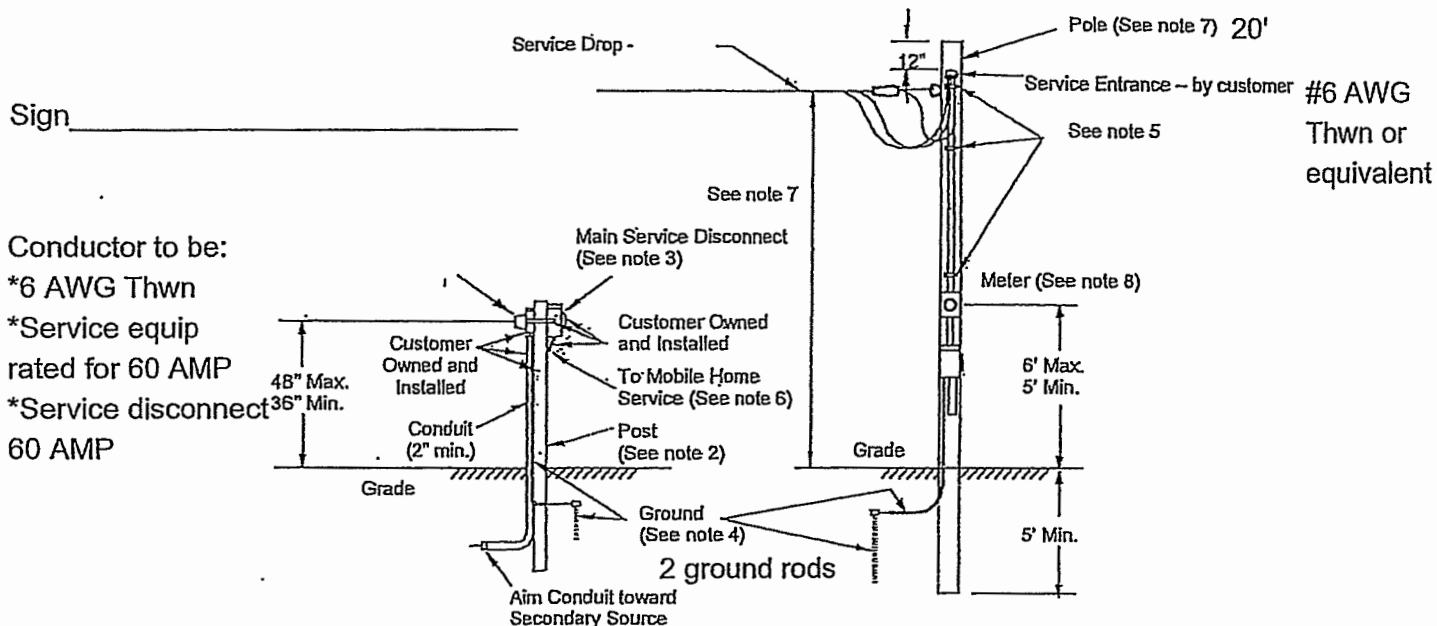

Conductor to be:

*6 AWG Thwn

*Service equip

rated for 60 AMP

*Service disconnect

60 AMP

NOTE: 2 ground rods must be exposed for inspection

NOTES:

1. Space under meter socket on post to be reserved for conduit.
2. Post to be constructed of reinforced concrete (5"x5"), fiberglass (6"x6" minimum), pressure treated wood (4"x4" minimum), 2" galvanized steel pipe with 2" concrete encasement below ground level, or equivalent.
3. Circuit breaker or main service fused disconnect (outdoor type) National Electrical Code.
4. The customer must ground facilities as required by the National Electrical Code and applicable local codes (refer to section VIII of this FPL Electric Service Standards issue).
5. Customer will install a sufficient number of conduit straps to properly secure conduit to pole.
6. Customer service may be run underground in conduit from bottom of main switch.
7. Customer's class 6 or 7 pressure treated wood pole, or equivalent, set a minimum of 5' deep. Must provide minimum service drop clearances shown in Figure IV-5.
8. Meter - Furnished and installed by FPL. Meter socket furnished and installed by customer.

2 Ground rods

****WELL MUST BE INSTALLED PRIOR TO FINAL INSPECTION AND POWER RELEASE****